



## Dare to be Square



*From an initial range of traditional freestanding bathtubs, Telford, UK-based Victoria and Albert Bathtubs, have expanded into the design-driven market with a range of uniquely contemporary tubs. Cobalt™ CAD and 3D modeling software has helped design Kevin Quigley keep pace and detail his ideas.*

Given only the size as a starting point, Kevin Quigley took up the challenge of designing a totally unique and contemporary tub for Victoria and Albert Bathtubs, creating the Capri. Kevin needed to explore options for the basic forms as quickly as possible. With the associative 3D solid and surface modeling features in Cobalt, Kevin was able to create six different concepts rendered in gray scale in only a few hours. He told us that in a product like Solidworks this would have taken an entire day, and each concept would have doubled the time and cost. In addition, half way through the design process, Victoria and Albert needed to make a significant change to the front of the tub. Because of Kevin's confidence in Cobalt he was able to say, 'Sure, no problem.' As he puts it:

***"In Solidworks this major design revision would have been a serious problem. It would have been easier to start from scratch. But Cobalt's flexible history-tree feature allowed me to make the changes in only half an hour—and Cobalt updated 10 associated drawings automatically."***

To allow the Victoria and Albert representatives to see the effect various designs had on material thickness and lumbar support, Kevin utilized the flexible sectioning feature in Cobalt.

The final design for the Capri was developed completely in Cobalt, including the renderings, Viewpoint 3D web viewing files and full production drawings. Kevin commented, "The Viewpoint export from Cobalt is excellent. You can even get inside the tub!" With the customer based in Telford and the production and tooling facility in South Africa, Cobalt's outstanding viewing files, and PDFs of renderings and drawings, played a critical part in quickly assessing and finalizing the project.

The final result for Quigley Design? Another success...the Capri is now one of the top selling bathtubs at Victoria and Albert.



Using the associative 3D solid and surface modeling in Cobalt, Kevin was quickly able to create several variations of the bath for the client to choose.

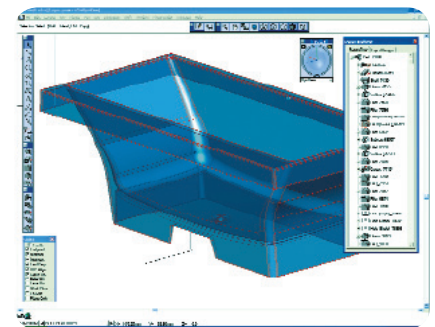

### Background/Contact

For more details on this project contact:

**Quigley Design**  
Westgate House, Hills Lane,  
Shrewsbury,  
Shropshire, SY1 1Q  
United Kingdom  
+44 (0) 1743 231661

[kevin.quigley@kqd.co.uk](mailto:kevin.quigley@kqd.co.uk)