

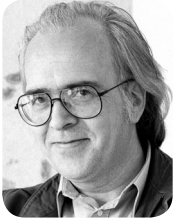

## Xenon™ Changes Designer's Point of View



For over 24 years John Bicht continued to use paper and pencil every time he wanted to design a new product. Then he found Graphite™ and was amazed at the fluidity with which he could communicate his ideas. But while he was quite adept at visualizing the final product in 2D wireframe drawings, his customers were not. So for marketing purposes he rather reluctantly moved to Xenon™, one of Ashlar-Vellum's 3D solid and surface modelling programs. Now he'll never go back.

Bicht admits that he struggled a bit to learn 3D modelling. "There were so many tools to use, surfacing, solids, rendering qualities, and so forth." But he successfully completed a redesign of a part for Versalab's original espresso machine while he was learning Xenon. Some months later he needed to redesign another of their espresso makers. This time he really didn't need Xenon's 3D rendering capabilities, however, as Bicht put it:

***"The thing that was odd to me was the realization that I only wanted to do the redesign in Xenon. While initially harder to learn than Graphite, Xenon's rich 3D capabilities, once learned, provided several huge advantages over simply working in 2D wireframe."***

The first advantage was speed. Bicht found he could create a block in one step rather than moving from side view to front view, creating multiple rectangles. The block would appear in any view of a manufacturing drawing without copying and pasting. He could modify parts just as a machine tool would, removing material from a solid, cutting shapes or blending edges. He could view the result from any angle of the 3D model and instantly see it in his manufacturing drawing.

The second advantage was accuracy. The complexity of Bicht's designs demanded more than the usual number of views. Using Xenon, Bicht only needed to change the 3D model once and all of the views were automatically updated using Xenon's associativity. No longer does he waste time and money manufacturing parts that don't fit correctly because they were generated from a view that has not been updated.

Finally, Bicht likes Xenon's rendering tools. "The ability to see the product rendered in 3D is very helpful in explaining things to others. I also get a better view myself."

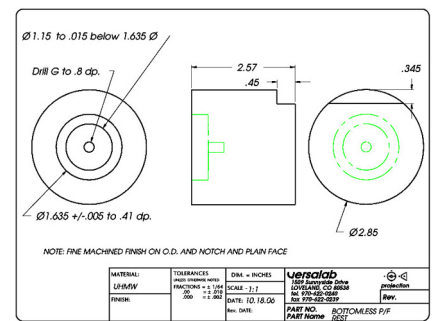
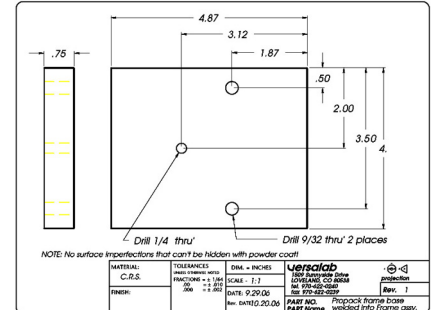

Bicht used Xenon for the speed and accuracy of its 3D modelling, plus Xenon's excellent photo-realistic rendering tools to redesign parts for the Propack Espresso system.



### Background/Contact

For more details on this project contact:

**John Bicht**

**Versalab**

3890 Saulcy Ct.  
Loveland, CO 80537

+1 970 622-0240

[john@versalab.com](mailto:john@versalab.com)

[www.versalab.com](http://www.versalab.com)